

SINGLE TO DOUBLE FORKLIFT AGV

SPECIFICATIONS



**SOUTHEAST
INTEGRATED
SOLUTIONS**

powered by



Southeast Industrial Equipment powered by AIM

📍 Charlotte, NC

☎ 704.737.1890

🌐 sieagvspoweredbyaim.com

HIGHLIGHTS

Single to double forklift AGVs (Automated Guided Vehicles) are versatile, autonomous material handling solutions designed to transport loads efficiently in warehouses and distribution centers. These AGVs are capable of adjusting their forks to handle both single and double pallet loads, providing flexibility for various storage and retrieval tasks. Single to double forklift AGVs optimize workflow by reducing manual labor, increasing throughput, and ensuring precise handling of materials. With their advanced navigation systems and adaptability, they streamline operations and contribute to improved productivity and cost savings in demanding environments.



WEIGHT CAPACITY
Up to 3,100lbs.



BATTERY TYPE
LEAD ACID



NAVIGATION
LASER GUIDANCE



CHARGING TYPE
FAST CHARGE



TRAVEL CAPABILITY
BI-DIRECTIONAL



LIFT HEIGHT
Up to 110"



AGV SPECIFICATIONS

General Specifications

Type: Single to Double Forklift Automated Guided Vehicle (AGV)

Model Name/Number: eBOTSD1248

Manufacturer: America in Motion

Operation Mode: Autonomous

Navigation Type: Laser-guided

Battery Type: Lead Acid

Battery Capacity: 48V, 380Ah

Charging Type: Fast Charging

Indoor/Outdoor Use: Indoor

Customization: Standard options available

Performance & Load Handling

Maximum Load Capacity (Max for flat surfaces only): Up to 3,100 lbs.

Load Center: 24"

Travel Capability: Bi-Directional

Standard Lift Height: Up to 110" (taller lift height options available)

Fork Length: 48"

Standard Travel Speed: 1.2 m/s

Standard Lift Speed: 6 in/sec

Mast Type: 2 stage ball screw for precision

Standard Gradient Capability: 0 deg

Turning Radius: 80"

Safety Features

Emergency Stop Button: Yes

Obstacle Detection: Yes

Safety Bumpers: Yes

Anti-collision Sensors: Yes

Interface & Control

User Interface: [Touchscreen / Button panel / Mobile app / Remote control]

Communication Protocol: [Wi-Fi / Bluetooth / Ethernet / 5G]

Software Integration: [Warehouse Management System (WMS), ERP, or other integrations]

Price & Warranty

Price Range: Contact SIE

Warranty: 1 year



TURNING RADIUS

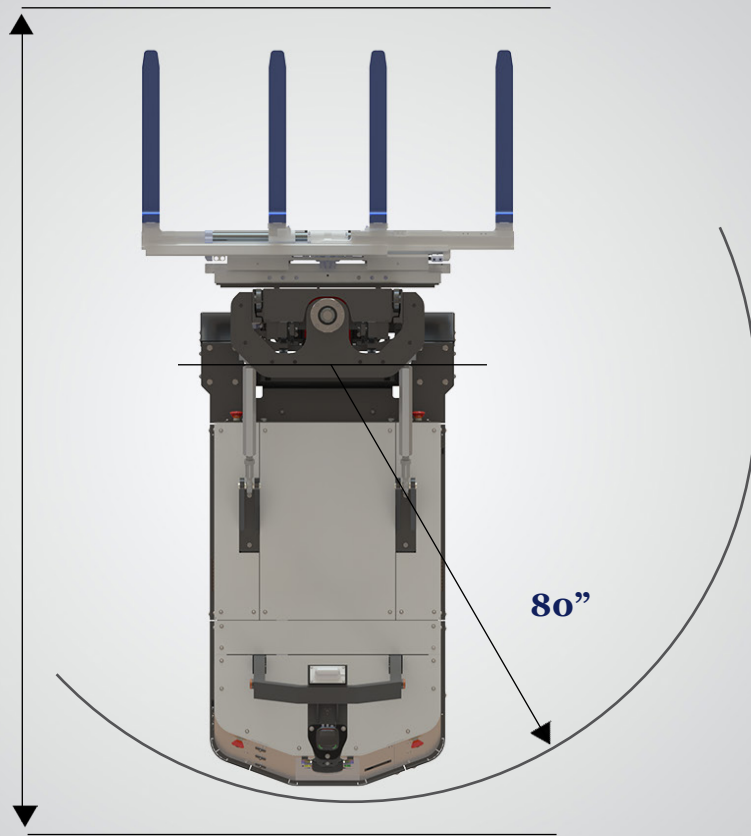

SAFETY FIELD

Warning Field - up to 25 meters @ 40 mm object resolution

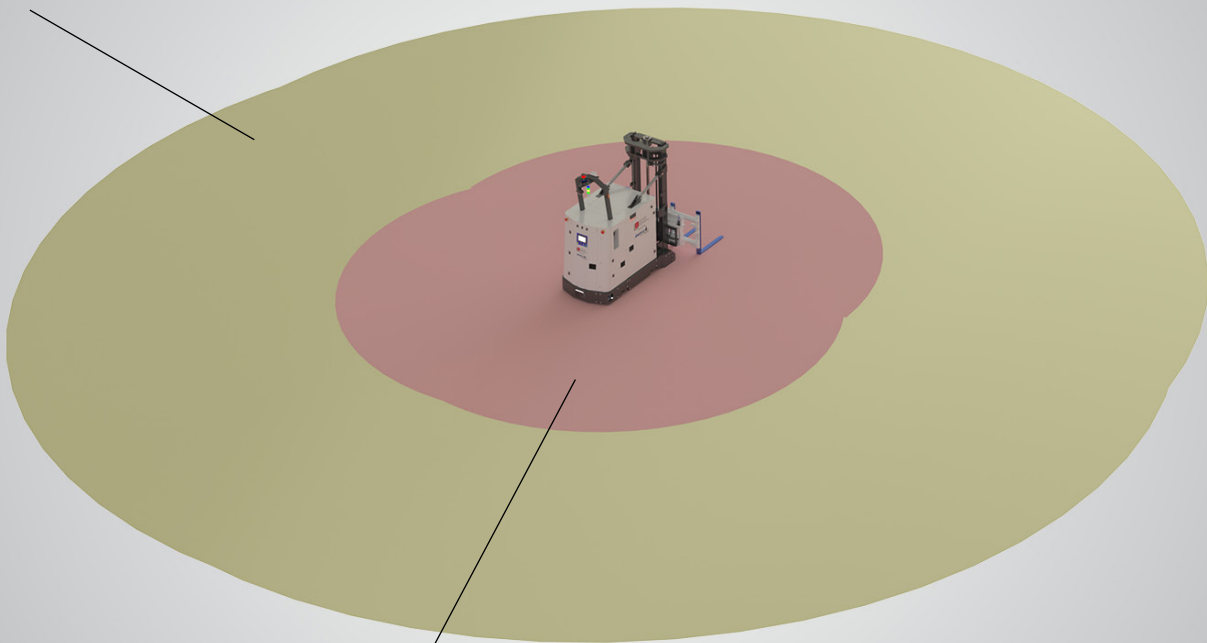

Protective Field - up to 4 meters @ 40 mm object resolution



VEHICLE QUANTITY CHART

The chart below helps determine the optimal number of AGVs needed for an operation by looking at round-trip distance and loads moved per hour. By matching these variables in the chart, you can calculate the required fleet size to meet material handling demands efficiently. For example, moving 20 loads per hour, 800 feet round trip would require 3 AGVs.

Round Trip Distance (Meters)	Round Trip Distance (Feet)	Loads/Hr.													
		10	15	20	25	30	35	40	45	50	55	60	65	70	
8	25	0.2	0.3	0.3	0.4	0.5	0.6	0.7	0.8	0.9	0.9	1.0	1.1	1.2	
15	50	0.2	0.3	0.4	0.5	0.6	0.8	0.9	1.0	1.1	1.2	1.3	1.4	1.5	
23	75	0.3	0.4	0.5	0.6	0.8	0.9	1.0	1.2	1.3	1.4	1.6	1.7	1.8	
30	100	0.3	0.5	0.6	0.8	0.9	1.1	1.2	1.4	1.5	1.7	1.8	2.0	2.1	
38	125	0.3	0.5	0.7	0.9	1.0	1.2	1.4	1.6	1.7	1.9	2.1	2.2	2.4	
46	150	0.4	0.6	0.8	1.0	1.2	1.4	1.6	1.7	1.9	2.1	2.3	2.5	2.7	
53	175	0.4	0.6	0.9	1.1	1.3	1.5	1.7	1.9	2.2	2.4	2.6	2.8	3.0	
61	200	0.5	0.7	1.0	1.2	1.4	1.7	1.9	2.1	2.4	2.6	2.9	3.1	3.3	
69	225	0.5	0.8	1.0	1.3	1.6	1.8	2.1	2.3	2.6	2.9	3.1	3.4	3.6	
76	250	0.6	0.8	1.1	1.4	1.7	2.0	2.2	2.5	2.8	3.1	3.4	3.7	3.9	
84	275	0.6	0.9	1.2	1.5	1.8	2.1	2.4	2.7	3.0	3.3	3.6	3.9	4.2	
91	300	0.6	1.0	1.3	1.6	1.9	2.3	2.6	2.9	3.2	3.6	3.9	4.2	4.5	
99	325	0.7	1.0	1.4	1.7	2.1	2.4	2.8	3.1	3.5	3.8	4.2	4.5	4.8	
107	350	0.7	1.1	1.5	1.8	2.2	2.6	2.9	3.3	3.7	4.0	4.4	4.8	5.2	
114	375	0.8	1.2	1.6	1.9	2.3	2.7	3.1	3.5	3.9	4.3	4.7	5.1	5.5	
122	400	0.8	1.2	1.6	2.1	2.5	2.9	3.3	3.7	4.1	4.5	4.9	5.3	5.8	
130	425	0.9	1.3	1.7	2.2	2.6	3.0	3.5	3.9	4.3	4.8	5.2	5.6	6.1	
137	450	0.9	1.4	1.8	2.3	2.7	3.2	3.6	4.1	4.5	5.0	5.5	5.9	6.4	
145	475	1.0	1.4	1.9	2.4	2.9	3.3	3.8	4.3	4.8	5.2	5.7	6.2	6.7	
152	500	1.0	1.5	2.0	2.5	3.0	3.5	4.0	4.5	5.0	5.5	6.0	6.5	7.0	
160	525	1.0	1.6	2.1	2.6	3.1	3.6	4.2	4.7	5.2	5.7	6.2	6.8	7.3	
168	550	1.1	1.6	2.2	2.7	3.3	3.8	4.3	4.9	5.4	6.0	6.5	7.0	7.6	
175	575	1.1	1.7	2.3	2.8	3.4	3.9	4.5	5.1	5.6	6.2	6.8	7.3	7.9	
183	600	1.2	1.8	2.3	2.9	3.5	4.1	4.7	5.3	5.9	6.4	7.0	7.6	8.2	
190	625	1.2	1.8	2.4	3.0	3.6	4.2	4.9	5.5	6.1	6.7	7.3	7.9	8.5	
198	650	1.3	1.9	2.5	3.1	3.8	4.4	5.0	5.7	6.3	6.9	7.5	8.2	8.8	
206	675	1.3	2.0	2.6	3.3	3.9	4.6	5.2	5.9	6.5	7.2	7.8	8.5	9.1	
213	700	1.3	2.0	2.7	3.4	4.0	4.7	5.4	6.0	6.7	7.4	8.1	8.7	9.4	
221	725	1.4	2.1	2.8	3.5	4.2	4.9	5.5	6.2	6.9	7.6	8.3	9.0	9.7	
229	750	1.4	2.1	2.9	3.6	4.3	5.0	5.7	6.4	7.2	7.9	8.6	9.3	10.0	
236	775	1.5	2.2	2.9	3.7	4.4	5.2	5.9	6.6	7.4	8.1	8.8	9.6	10.3	
244	800	1.5	2.3	3.0	3.8	4.6	5.3	6.1	6.8	7.6	8.3	9.1	9.9	10.6	
251	825	1.6	2.3	3.1	3.9	4.7	5.5	6.2	7.0	7.8	8.6	9.4	10.1	10.9	
259	850	1.6	2.4	3.2	4.0	4.8	5.6	6.4	7.2	8.0	8.8	9.6	10.4	11.2	
267	875	1.6	2.5	3.3	4.1	4.9	5.8	6.6	7.4	8.2	9.1	9.9	10.7	11.5	
274	900	1.7	2.5	3.4	4.2	5.1	5.9	6.8	7.6	8.5	9.3	10.1	11.0	11.8	
282	925	1.7	2.6	3.5	4.3	5.2	6.1	6.9	7.8	8.7	9.5	10.4	11.3	12.1	
290	950	1.8	2.7	3.6	4.4	5.3	6.2	7.1	8.0	8.9	9.8	10.7	11.6	12.4	
297	975	1.8	2.7	3.6	4.6	5.5	6.4	7.3	8.2	9.1	10.0	10.9	11.8	12.8	





Southeast Industrial Equipment powered by AIM

CONTACT:

 Charlotte, NC

 704.737.1890

 sieagvspoweredbyaim.com

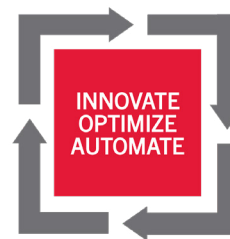

**SOUTHEAST
INTEGRATED
SOLUTIONS**

powered by

